

800E PRO LANDING SKID ASSEMBLY ILLUSTRATION

800E PRO 腳架組裝示意圖

ALIGN

Primary hole position designed for T-REX 700E/700E DFC/800E PRO DFC

原孔位適用於：T-REX 700E/700E DFC/800E PRO DFC

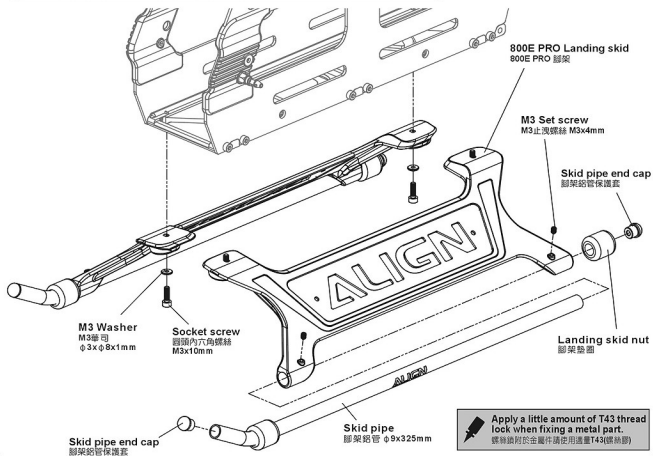

The drilling hole position suitable for T-REX 700N DFC/800E TREKKER

鑽孔孔位適用於：T-REX 700N DFC/800E TREKKER

For T-REX 700N DFC/800E TREKKER models, please refer to below illustration, accordingly drill the hole by using φ3mm drill tool.

T-REX 700N DFC/800E TREKKER 機型，請參考下圖指示之位置，使用φ3鑽孔工具來進行鑽孔。

ADDITIONAL TOOLS
REQUIRED FOR ASSEMBLY
自備工具

Drill
鑽頭 φ3mm x1

